



X11SRA
X11SRA-F
X11SRA-RF

ENGLISH

繁體中文

简体中文

日本語

한국어

QUICK REFERENCE GUIDE

Revision 1.0

Standardized Warning Statements

Motherboards

About Standardized Warning Statements

The following statements are industry standard warnings, provided to warn the user of situations which can potentially cause a bodily injury. Should you have questions or experience difficulty, contact Supermicro's Technical Support Department for assistance. Only certified technicians should attempt to install or configure components.

Read this section in its entirety before installing or configuring components in the Supermicro chassis.

Battery Handling



Warning!

There is a danger of explosion if the battery is replaced incorrectly. Replace the battery only with the same or an equivalent type recommended by the manufacturer. Dispose of used batteries according to the manufacturer's instructions.

警告

電池更換不當會有爆炸危險。請使用製造商建議之相同或功能相當的電池更換原有電池。請按照製造商的說明指示處理廢棄舊電池。

警告

電池更換不當會有爆炸危險。請只使用同類電池或製造商推薦的功能相當的電池更換原有電池。請按製造商的說明處理廢舊電池。

電池の取り扱い

電池交換が正しく行われなかった場合、破裂の危険性があります。交換する電池はメーカーが推奨する型、または同等のものを使用下さい。使用済電池は製造元の指示に従って処分して下さい。

경고!

배터리가 올바르게 교체되지 않으면 폭발의 위험이 있습니다. 기존 배터리와 동일하거나 제조사에서 권장하는 동등한 종류의 배터리로만 교체해야 합니다. 제조사의 안내에 따라 사용된 배터리를 처리하여 주십시오.

هناك خطر من انفجار في حالة استبدال البطارية بطريقة غير صحيحة فعلياً
استبدال البطارية
فقط بنفس النوع أو ما يعادلها كما أوصت به الشركة المصنعة
تخلص من البطاريات المستعملة وفقاً لتعليمات الشركة الصانعة

限用物質含有情況標示聲明書

Declaration of the Presence Condition of the Restricted Substances Marking

設備名稱：主機板 / Motherboard Equipment name		型號 (型式) : X11SRA, X11SRA-F, X11SRA-RF Type designation (Type)				
單元 Unit	限用物質及其化學符號 Restricted substances and its chemical symbols					
	鉛Lead (Pb)	汞Mercury (Hg)	鎘Cadmium (Cd)	六價鉻 Hexavalent chromium (Cr ⁺⁶)	多溴聯苯 Polybrominated biphenyls (PBB)	多溴二苯醚 Polybrominated diphenyl ethers (PBDE)
主機板 (Motherboard)	—	○	○	○	○	○
備考1. “超出0.1 wt %” 及 “超出0.01 wt %” 係指限用物質之百分比含量超出百分比含量基準值。 Note 1 : “Exceeding 0.1 wt %” and “exceeding 0.01 wt %” indicate that the percentage content of the restricted substance exceeds the reference percentage value of presence condition.						
備考2. “○” 係指該項限用物質之百分比含量未超出百分比含量基準值。 Note 2 : “○” indicates that the percentage content of the restricted substance does not exceed the percentage of reference value of presence.						
備考3. “—” 係指該項限用物質為排除項目。 Note 3 : The “—” indicates that the restricted substance corresponds to the exemption.						

AMI BIOS POST Codes

About AMI BIOS POST Codes

The table below lists some of AMI BIOS POST codes for X11SRA/F/-RF. For more information, refer to https://www.supermicro.com.tw/manuals/other/AMI_BIOS_POST_Codes_for_Grantley_Motherboards.pdf.

Code	Description
0x32	CPU post-memory initialization is started
0x55	No Memory detected or memory failed
0x63	CPU DXE initialization is started
0x69	North Bridge DXE initialization is started
0x70	South Bridge DXE initialization is started
0x92	PCI Bus initialization is started
0x99	Super IO Initialization
0x9A	USB initialization is started
0xA0	IDE initialization is started
0xA9	Boot into BIOS setup menu
0xAE	Legacy Boot event
0xB2	Legacy Option ROM Initialization
0xB4	USB hot plug
0xD6	No VGA device
0xD7	No Keyboard plug in
0xF2	Recovery process started
0xF9	Recovery capsule is not found

M.2 Device Installation and Removal Instructions

M.2 Device Installation

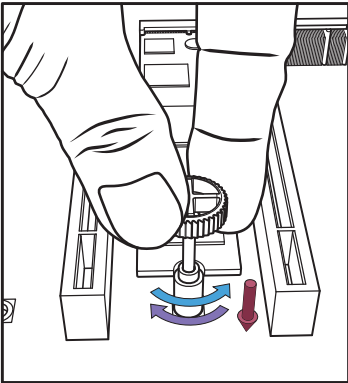
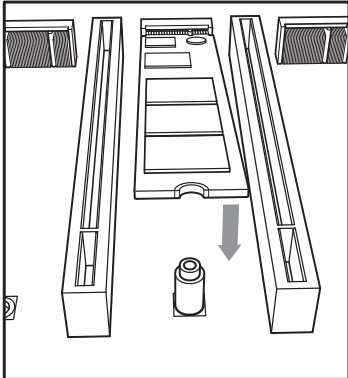
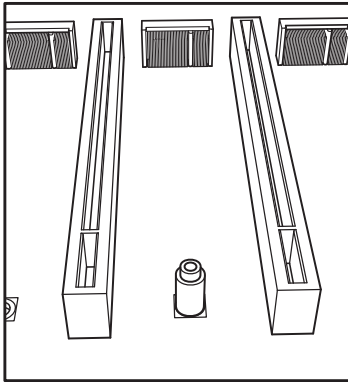

M.2 Device Removal

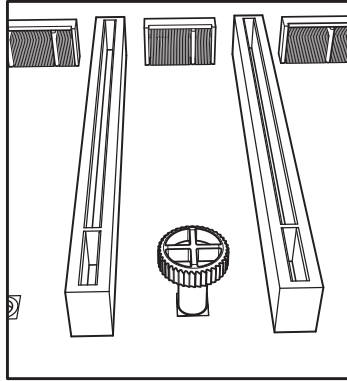
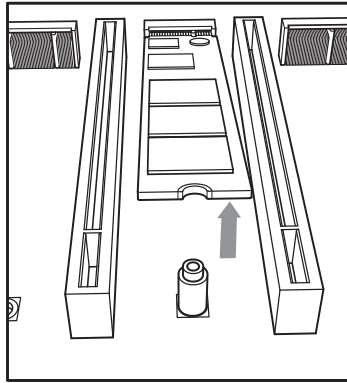
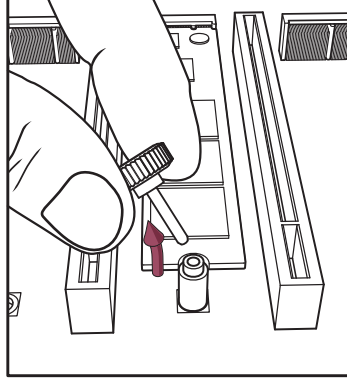
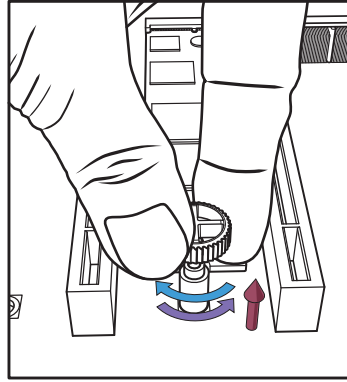

Motherboard Layout and Features

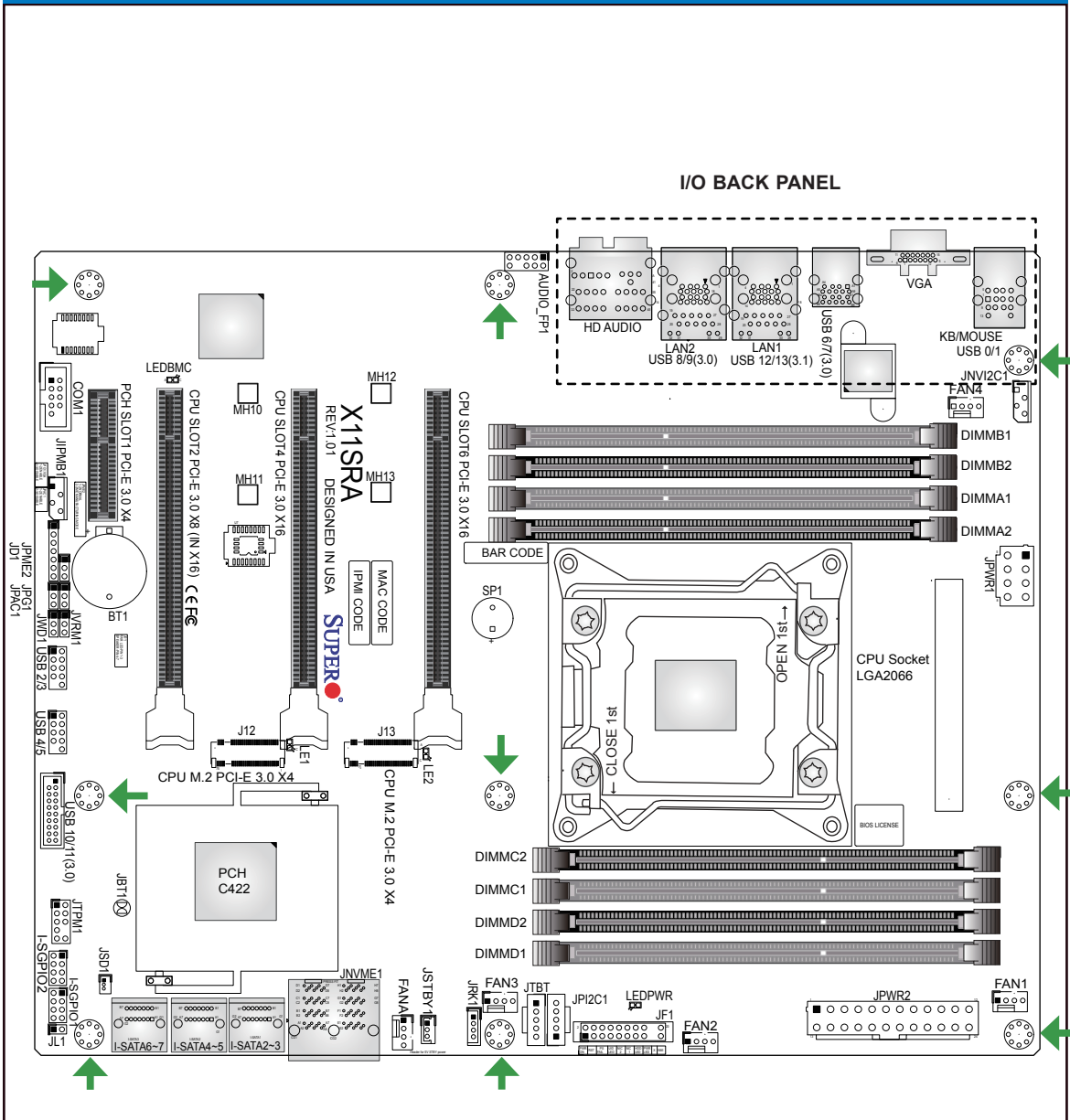

→ = mounting hole

PACKAGE CONTENTS

- One (1) Supermicro Motherboard
- Six (6) SATA Cables, One (1) I/O Shield
- One (1) Quick Reference, One (1) Driver CD

Jumpers and Connectors

Jumpers

Jumper	Description	Default
JBT1	CMOS Clear	Open: Normal, Closed: Clear CMOS
JPAC1	Audio Enable	Pins 1-2 (Enabled)
JPG1	VGA Enable	Pins 1-2 (Enabled)
JPME2	Manufacturing Mode Select	Pins 1-2 (Normal)

Connectors

Connector	Description
AUDIO_FP1	Front Panel Audio Header
BT1	Onboard Battery
COM1	COM Header
FAN1 ~ FAN4, FANA	System/CPU Fan Headers
HD AUDIO	High Definition Audio Header
I-SATA2/3, I-SATA4/5, I-SATA6/7	SATA 3.0 Connectors
I-SGPIO 1/2	Serial Link General Purpose I/O Headers
J12	M.2 PCI-E 3.0 x4 Slot
J13	M.2 PCI-E 3.0 x4 Slot
JD1	Speaker/Power LED Indicator (Pins 1-3: Power LED, Pins 4-7: Speaker)
JF1	Front Control Panel Header
JIPMB1	System Management Bus Header (for IPMI only)
JL1	Chassis Intrusion Header
JNVME1	NVMe Connector (supports two connections)
JNVI2C1	NVMe I2C Header
JPI2C1	Power I2C System Management Bus (Power SMB) Header (X11SRA-F/-RF only)
JPWR1	+12V 8-pin CPU Power Connector (Required)
JPWR2	24-pin ATX Main Power Connector (Required)
JRK1	Intel® RAID Key Header
JSD1	SATA Disk On Module (DOM) Power Connector
JSTBY1	Standby Power Header
JTBT	Thunderbolt Header
JTPM1	Trusted Platform Module (TPM)/Port 80 Connector
LAN1/LAN2	LAN1: 5 Gigabit (RJ45) LAN Port, LAN2: 1 Gigabit (RJ45) LAN Port
MH10 ~ MH13	M.2 Holding Screws
SLOT1	PCI-E 3.0 x4 PCH Slot
SLOT2	PCI-E 3.0 x8 (IN x16) CPU Slot
SLOT4, SLOT6	PCI-E 3.0 x16 CPU Slots
SP1	Internal Speaker/Buzzer
USB 0/1	Back Panel USB 2.0 Ports
USB 2/3, USB 4/5	Front Accessible USB 2.0 Headers
USB 6/7, USB 8/9	Back Panel USB 3.0 Ports
USB 10/11	Front Accessible USB 3.0 Type A Header
USB 12/13	Back Panel USB 3.1 Ports
VGA	Back Panel VGA Port

NOTES

- Graphics shown in this quick reference guide are for illustration only. Your components may or may not look exactly the same as drawings shown in this guide.
- Refer to Chapter 2 of the User Manual for detailed information on jumpers, connectors, LED indicators, memory support and CPU/motherboard installation instructions.

CPU Installation

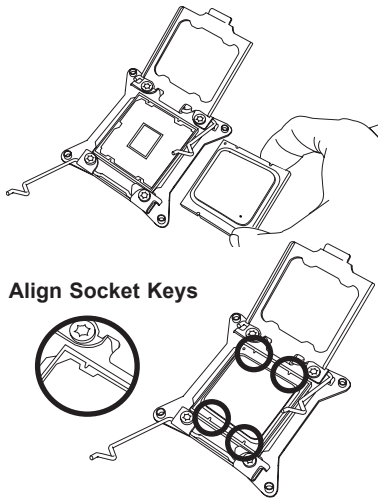

Heatsink Installation

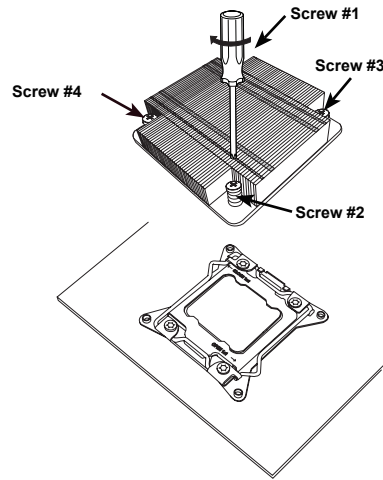

Front Control Panel (JF1)

	1	2	
Power Button { PWR	○	○	Ground
Reset Button { Reset	○	○	Ground
3.3 V	○	○	Power Fail LED
Red+ (Blue LED Cathode)	○	○	Blue+ (OH/Fan Fail)
3.3V Stby	○	○	NIC2 Activity LED
3.3V Stby	○	○	NIC1 Activity LED
3.3V Stby	○	○	HDD LED
3.3V	○	○	PWR LED
X	○	○	X
NMI	○	○	Ground
	19	20	

Back Panel I/O Connectors

A. PS/2 Keyboard/Mouse Port	F. USB 3.0 Port 7	K. USB 3.0 Port 8	P. Line In
B. USB 2.0 Port 0	G. 5Gb LAN Port 1	L. USB 3.0 Port 9	Q. Line Out
C. USB 2.0 Port 1	H. USB 3.1 Port 12	M. Center/LFE Out	R. Mic In
D. VGA Port	I. USB 3.1 Port 13	N. Surround Out	
E. USB 3.0 Port 6	J. 1Gb LAN Port 2	O. S/PDIF Out	

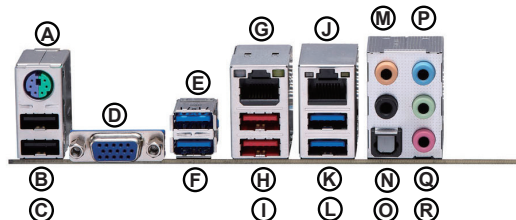

X11SRA



MNL-2005-QRG-100

© 2017 Supermicro Computer, Inc. All rights reserved. Reproduction of this document whether in part or in whole is strictly prohibited without Supermicro's written consent. All trademarks are property of their respective entities. All information provided is deemed accurate at the time of printing; however, it is not guaranteed.

主機板元件配置圖

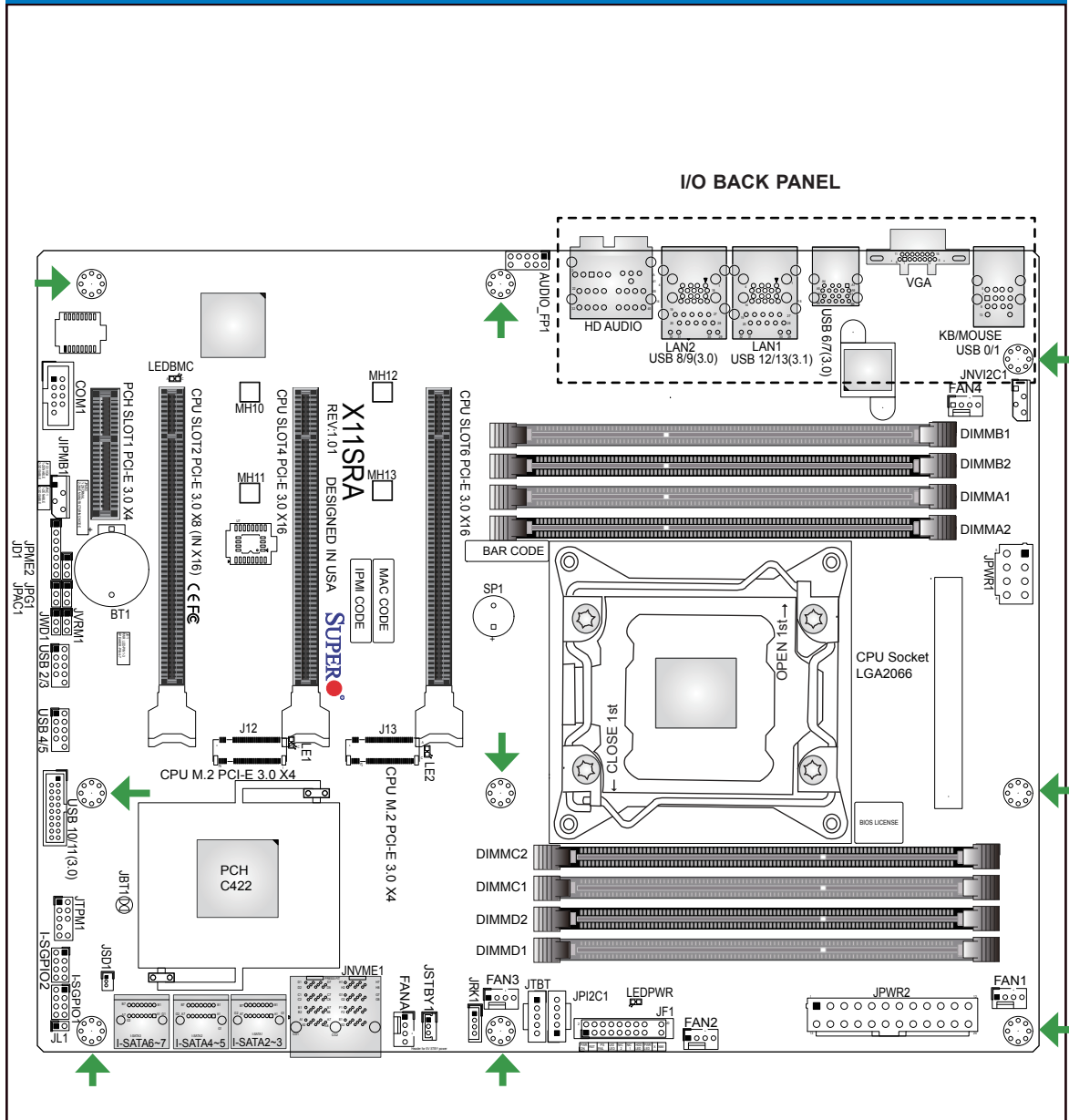

→ = 裝機孔

單一主機板包裝盒內容清單

- Supermicro X11SRA-F/-RF 主機板 x1
- SATA 訊號線 x6
- 後檔板 x1
- 快速參考指南 x1
- 驅動程式光碟片 x1

跳線器/連接埠

跳線器 (Jumper)		
跳線器	說明	預設值
JBT1	CMOS (可讀寫隨機存取記憶體晶片) 組態資料清除	開啟：正常 · 關閉：清除 CMOS
JPAC1	啟用音源	針腳 1-2 (啟用)
JPG1	啟用 VGA 連接埠	針腳 1-2 (啟用)
JPME2	製造模式選擇	針腳 1-2 (正常)
連接埠 (Connector)		
連接埠	說明	
AUDIO_FP1	前面板音效接頭	
BT1	內建電池	
COM1	COM1 序列連接埠	
FAN1 ~ FAN4, FANA	系統及中央處理器 (CPU) 風扇接頭	
HD AUDIO	背板高清晰音效插孔	
I-SATA2/3, I-SATA4/5, I-SATA6/7	SATA 3.0 連接埠	
I-SGPIO 1/2	序列通用 I/O 傳輸插座	
J12/J13	M.2 PCI-E 3.0 x4 介面連接埠 (註：PCI-E 為電腦匯流的一種規格，而 M.2 為固態硬碟的一種傳輸介面。)	
JD1	喇叭/電源 LED 指示燈 (針腳 1-3：電源 LED 指示燈 · 針腳 4-7：喇叭)	
JF1	前控制面板接頭	
JIPMB1	系統管理匯流排 (SMBus) 接頭 (僅適用於 IPMI)	
JL1	機殼防盜裝置接頭	
JNVME1	NVMe 接頭 (supports two connections)	
JNVI2C1	NVMe I2C 接頭	
JPI2C1	電源供應 PMBus 接頭 (僅限 X11SRA-F/-RF)	
JPWR1	+12伏特8針腳 CPU 電源連接埠 (必備)	
JPWR2	24針腳 ATX 主電源連接埠 (必備)	
JRK1	Intel® RAID Key 接頭	
JSD1	SATA DOM (磁碟模組) 電源連接埠	
JSTBY1	待機電源接頭	
JTBT	Thunderbolt 插座	
JTPM1	TPM 信任平台模組/Port 80 插座	
LAN1/LAN2	LAN1: 背板 5Gb (RJ45) LAN 網路線連接埠 · LAN2: 背板 1Gb (RJ45) LAN 網路線連接埠	
MH10 ~ MH13	M.2 固定孔	
SLOT1	PCI-E 3.0 x4 PCH 插槽	
SLOT2	PCI-E 3.0 x8 (IN x16) CPU 插槽	
SLOT4, SLOT6	PCI-E 3.0 x16 CPU 插槽	
SP1	內建蜂鳴器	
USB 0/1	背板 USB 2.0 規格連接埠 (註：USB 完整譯名為「通用序列匯流排」)	
USB 2/3, USB 4/5	前面板 USB 2.0 規格連接埠	
USB 6/7, USB 8/9	背板 USB 3.0 規格連接埠	
USB 10/11	前面板 USB 3.0 規格連接埠 (Type A)	
USB 12/13	背板 USB 3.1 規格連接埠	
VGA	背板 VGA 連接埠	

備註

- 快速參考指南中的圖例僅供安裝及操作說明使用，可能與實際產品外觀不同。
- 欲知更多跳線器/連接埠/指示燈/記憶體/主機板/中央處理器的安裝相關資訊，請參閱《SUPERMICRO X11SRA/-F/-RF 使用手冊》第二章。

中央處理器安裝方式

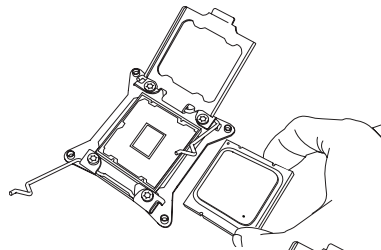

對齊校準缺口及校準點



散熱器安裝方式

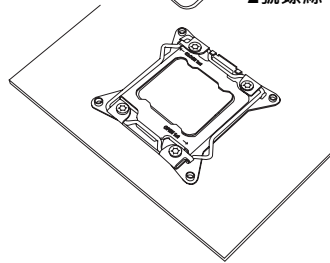
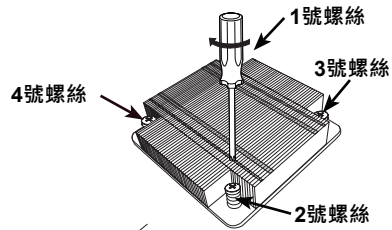

前控制面板配置 (JF1)

	1	2	
電源鍵 { PWR	○	○	接地
重設鍵 { Reset	○	○	接地
3.3伏	○	○	電源故障LED
3.3伏電源	○	○	亮紅燈 (過熱及風扇故障)
3.3伏電源	○	○	
3.3伏電源	○	○	網卡2之LED
3.3伏電源	○	○	網卡1之LED
3.3伏電源	○	○	硬碟機LED
3.3伏	○	○	電源LED
X	○	X	
非可遮蔽中斷	○	○	接地
	19	20	

	1	2	
Power Button { PWR	○	○	Ground
Reset Button { Reset	○	○	Ground
3.3 V	○	○	Power Fail LED
Red+ (Blue LED Cathode)	○	○	Blue+ (OH/Fan Fail)
3.3V Stby	○	○	NIC2 Activity LED
3.3V Stby	○	○	NIC1 Activity LED
3.3V Stby	○	○	HDD LED
3.3V	○	○	PWR LED
X	○	X	
NMI	○	○	Ground
	19	20	

背板輸出/輸入連接埠

A. PS/2 鍵盤 (滑鼠) 連接埠	F. USB 7 (3.0) 連接埠	K. USB 8 (3.0) 連接埠	P. 音效輸入
B. USB 0 (2.0) 連接埠	G. 5Gb LAN 1 網路線連接埠	L. USB 9 (3.0) 連接埠	Q. 音效輸出
C. USB 1 (2.0) 連接埠	H. USB 12 (3.1) 連接埠	M. 中央/低音聲道輸出	R. 麥克風插孔
D. VGA 連接埠	I. USB 13 (3.1) 連接埠	N. 環繞聲道輸出	
E. USB 6 (3.0) 連接埠	J. 1Gb LAN 2 網路線連接埠	O. S/PDIF 輸出	

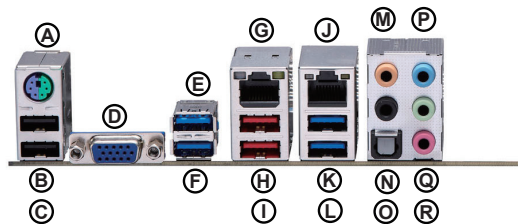

X11SRA

MNL-2005-QRG-100

© 2017 美超微股份有限公司 (以下簡稱「本公司」) 版權所有。未經本公司書面同意，嚴禁複製本文件部分或全部內容。所有商標均為所屬公司所有。所有提供資訊於印刷之際視為但不保證正確。

单一主板包装盒内容清单

- Supermicro X11SRA-F/-RF 主板 x1
- SATA 数据线 x6
- 后挡板 x1
- 快速参考指南 x1
- 驱动程序光盘 x1

跳帽/接口

跳帽 (Jumper)

跳帽	说明	预设值
JBT1	CMOS 配置数据清除 (板载)	开启：正常，关闭：清除 CMOS
JPAC1	启用音源	针脚 1-2 (启用)
JPG1	启用板载 VGA	针脚 1-2 (启用)
JPME2	制造模式选择	针脚 1-2 (正常)

接口 (Connector)

接口	说明
AUDIO_FP1	前面板音效接口
BT1	内建电池
COM1	COM1 串口
FAN1 ~ FAN4, FANA	系统及中央处理器 (CPU) 风扇接口
HD AUDIO	前面板高清音效接口
I-SATA2/3, I-SATA4/5, I-SATA6/7	SATA 3.0 接口
I-SGPIO 1/2	串行通用 I/O 传输接口
J12/J13	M.2 PCI-E 3.0 x4 接口 (注：PCI-E 为一种电脑总线规范，而 M.2 为一种固态硬盘接口规范。)
JD1	喇叭/电源 LED 指示灯 (针脚 1-3：电源 LED 指示灯，针脚 4-7：喇叭)
JF1	前控制面板接口
JIPMB1	系统管理总线 (SMBus) 接口 (仅适用于 IPMI)
JL1	机箱入侵检测接口
JNVME1	NVMe 接口 (supports two connections)
JNVI2C1	NVMe I2C 接口
JPI2C1	电源 PMBus 接口 (仅限 X11SRA-F/-RF)
JPWR1	+12伏特8针脚 CPU 电源接口 (必备)
JPWR2	24针脚 ATX 主电源接口 (必备)
JRK1	Intel® RAID Key 接口
JSD1	SATA DOM (磁盘模组) 电源接口
JSTBY1	待机电源接口
JTBT	Thunderbolt 接口
JTPM1	TPM 信任平台模组/Port 80 接口
LAN1/LAN2	LAN1: 5Gb (RJ45) LAN 网络接口 · LAN2: 1Gb (RJ45) LAN 网络接口
MH10 ~ MH13	M.2 固定孔
SLOT1	PCI-E 3.0 x4 PCH 插槽
SLOT2	PCI-E 3.0 x8 (IN x16) CPU 插槽
SLOT4, SLOT6	PCI-E 3.0 x16 CPU 插槽
SP1	板载蜂鸣器
USB 0/1	后挡板 USB 2.0 接口 (注：USB 完整译名为「通用串行总线」)
USB 2/3, USB 4/5	前面板 USB 2.0 接口
USB 6/7, USB 8/9	后挡板 USB 3.0 接口
USB 10/11	前面板 USB 3.0 接口 (Type A)
USB 12/13	后挡板 USB 3.1 接口
VGA	后挡板VGA 接口

备注

- 快速参考指南中的图例仅供安装及操作说明使用，可能与实际产品外观不同。
- 欲知更多跳帽/接口/指示灯/内存/主板/中央处理器的安装相关资讯，请参阅《SUPERMICRO X11SRA/-F/-RF 使用手册》第二章。

中央处理器安装方式

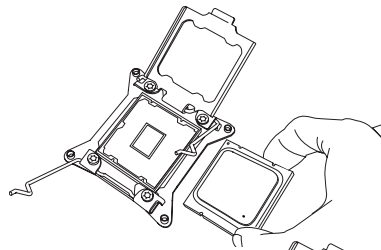

对齐校准缺口及校准点

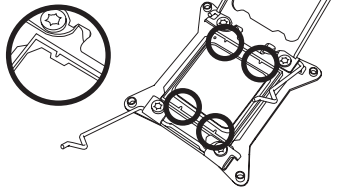

散热器安装方式

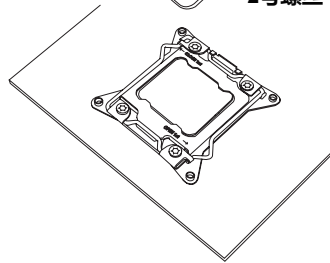
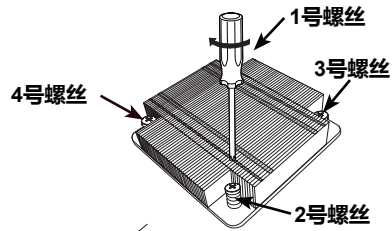

前控制面板配置 (JF1)

	1	2	
电源键 { PWR	○	○	接地
重置键 { Reset	○	○	接地
3.3伏	○	○	电源故障LED
3.3伏电源	○	○	亮红灯 (过热及风扇故障)
3.3伏电源	○	○	网卡2 LED
3.3伏电源	○	○	网卡1 LED
3.3伏电源	○	○	硬盘LED
3.3伏	○	○	电源LED
X	○	X	
不可屏蔽中断	○	○	接地
	19	20	

	1	2	
Power Button { PWR	○	○	Ground
Reset Button { Reset	○	○	Ground
3.3 V	○	○	Power Fail LED
Red+ (Blue LED Cathode)	○	○	Blue+ (OH/Fan Fail)
3.3V Stby	○	○	NIC2 Activity LED
3.3V Stby	○	○	NIC1 Activity LED
3.3V Stby	○	○	HDD LED
3.3V	○	○	PWR LED
X	○	X	
NMI	○	○	Ground
	19	20	

后挡板输出/输入接口

A. PS/2 键盘 (鼠标) 接口	F. USB 7 (3.0) 接口	K. USB 8 (3.0) 接口	P. 音效输入
B. USB 0 (2.0) 接口	G. 5Gb LAN 1 网络接口	L. USB 9 (3.0) 接口	Q. 音效输出
C. USB 1 (2.0) 接口	H. USB 12 (3.1) 接口	M. 中央/低音声道输出	R. 麦克风插孔
D. VGA 接口	I. USB 13 (3.1) 接口	N. 环绕声道输出	
E. USB 6 (3.0) 接口	J. 1Gb LAN 2 网络接口	O. S/PDIF 输出	

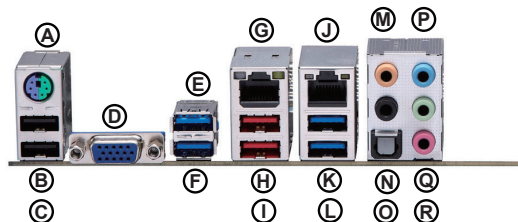

X11SRA

MNL-2005-QRG-100

© 2017 美超微股份有限公司 (以下简称「本公司」) 版权所有。未经本公司书面同意，严禁複製本文件部分内容或全部内容。所有商標均為所屬公司所有。所有提供資訊於印刷之際視為但不保證正確。

マザーボードのレイアウト、および、特徴

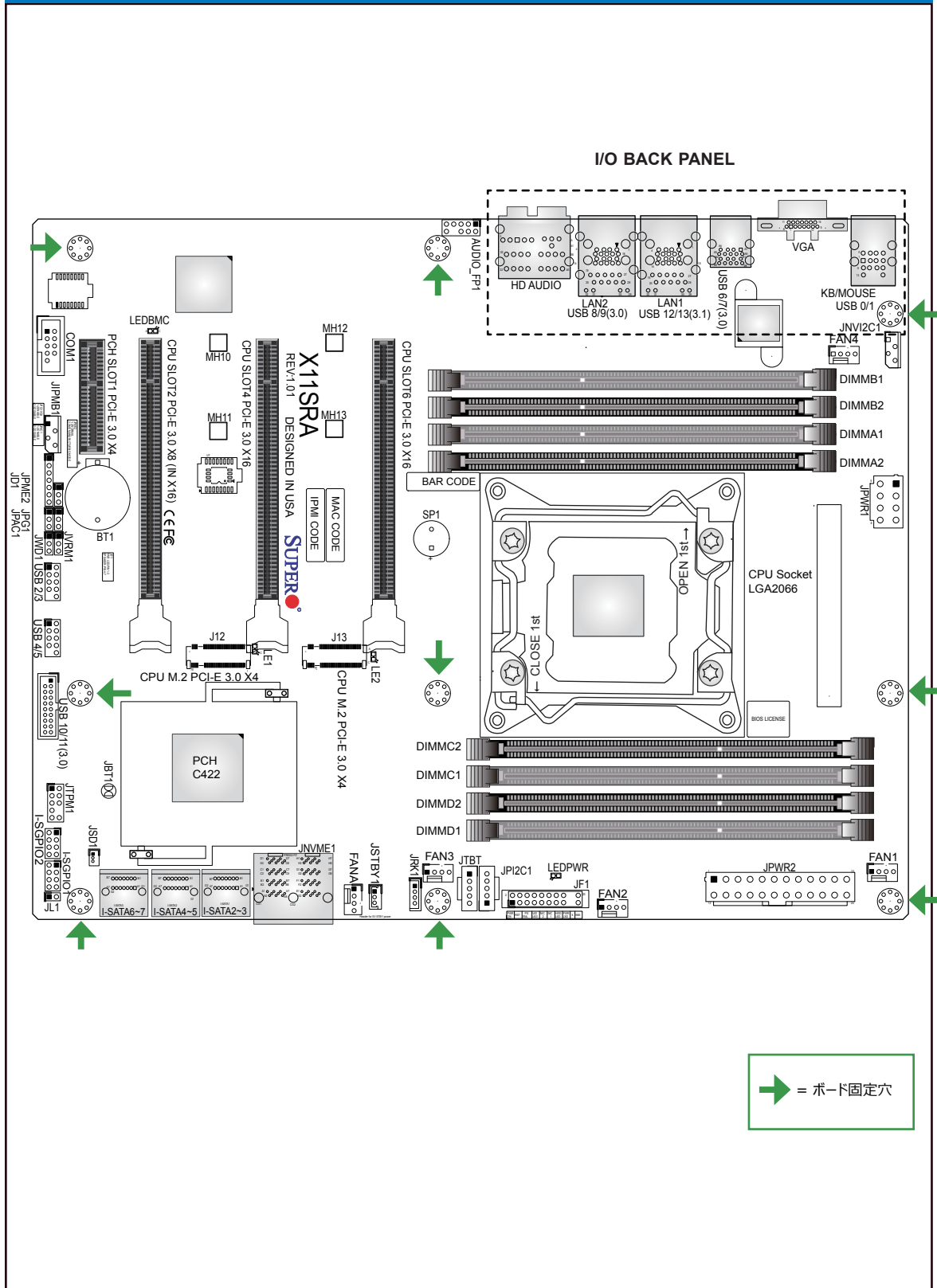

パッケージ内容

- Supermicro マザーボード × 1
- SATA ケーブル × 6, I/O シールド × 1
- クイック・リファレンス × 1, ドライバー CD × 1

ジャンパとコネクタ

ジャンパ

ジャンパ	説明	デフォルト
JBT1	CMOS クリア	オープン : ノーマル, クローズ : CMOS クリア
JPAC1	オーディオ 有効化	Pins 1-2 (有効)
JPG1	VGA 有効化	Pins 1-2 (有効)
JPME2	製造モード選択	Pins 1-2 (ノーマル)

コネクタ

コネクタ	説明
AUDIO_FP1	前面パネル・オーディオ・ヘッダー
BT1	オンボード・バッテリー
COM1	COM ヘッダー
FAN1 ~ FAN4, FANA	システム/CPU ファン・ヘッダー
HD AUDIO	ハイデフィニション・オーディオ・ヘッダー
I-SATA2/3, I-SATA4/5, I-SATA6/7	SATA 3.0 コネクタ
I-SGPIO 1/2	シリアルリンク 多用途 I/O ヘッダー
J12	M.2 PCI-E 3.0 x4 スロット
J13	M.2 PCI-E 3.0 x4 スロット
JD1	スピーカー/パワー LEDインジケータ (ピン 1-3: 電源LED, ピン 4-7: スピーカー)
JF1	前面コントロールパネル・ヘッダー
JIPMB1	システム管理バス・ヘッダー (IPMI用)
JL1	筐体開閉検出ヘッダー
JNVME1	NVMe コネクタ (2つの接続に対応)
JNVI2C1	NVMe I2C ヘッダー
JPI2C1	電源 I2C システム管理バス (Power SMB) ヘッダー (X11SRA-F/-RF のみ対象)
JPWR1	+12V 8-pin CPU 電源コネクタ (必須)
JPWR2	24-pin ATX 主電源コネクタ (必須)
JRK1	Intel® RAID キー ヘッダー
JSD1	SATA Disk On Module (DOM) 電源コネクタ
JSTBY1	スタンバイ電源ヘッダー
JTBT	Thunderbolt ヘッダー
JTPM1	Trusted Platform Module (TPM)/Port 80 コネクタ
LAN1/LAN2	LAN1: 5 Gigabit (RJ45) LAN ポート, LAN2: 1 Gigabit (RJ45) LAN ポート
MH10 ~ MH13	M.2 固定ネジ
SLOT1	PCI-E 3.0 x4 PCH スロット
SLOT2	PCI-E 3.0 x8 (IN x16) CPU スロット
SLOT4, SLOT6	PCI-E 3.0 x16 CPU スロット
SP1	内蔵スピーカー/ブザー
USB 0/1	背面パネル USB 2.0 ポート
USB 2/3, USB 4/5	前面アクセス可能 USB 2.0 ヘッダー
USB 6/7, USB 8/9	背面パネル USB 3.0 ポート
USB 10/11	前面アクセス可能 USB 3.0 Type A ヘッダー
USB 12/13	背面パネル USB 3.1 ポート
VGA	背面パネル VGA ポート

注

- クイック・リファレンス・ガイドに掲載されている図は参考イラストです。ご利用のコンポーネントは、本ガイドに掲載されている図と異なる場合があります。
- ジャンパ、コネクタ、LED表示、メモリ・サポート、CPU/マザーボードのインストール方法に関する詳細情報は、ユーザーマニュアルの第2章をご参照ください。

CPU のインストール

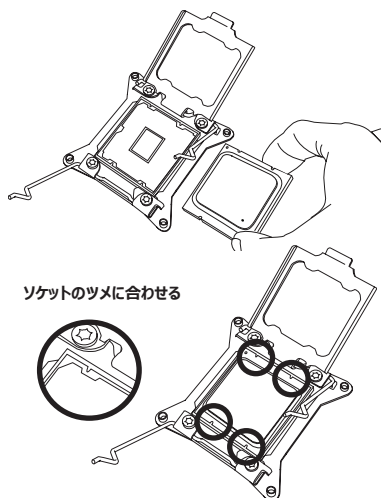

ヒートシンクのインストール

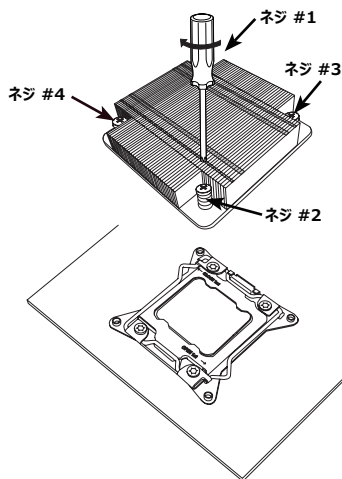

前面コントロール・パネル (JF1)

	1	2	
Power Button	PWR	○	Ground
Reset Button	Reset	○	Ground
	3.3 V	○	Power Fail LED
Red+ (Blue LED Cathode)	○	○	Blue+ (OH/Fan Fail)
	3.3V Stby	○	NIC2 Activity LED
	3.3V Stby	○	NIC1 Activity LED
	3.3V Stby	○	HDD LED
	3.3V	○	PWR LED
	X	○	X
	NMI	○	Ground
	19	20	

背面パネル I/O コネクタ

A. PS/2 キーボード/マウス ポート	F. USB 3.0 ポート 7	K. USB 3.0 ポート 8	P. ライン 入力
B. USB 2.0 ポート 0	G. 5Gb LAN ポート 1	L. USB 3.0 ポート 9	Q. ライン 出力
C. USB 2.0 ポート 1	H. USB 3.1 ポート 12	M. Center/LFE 出力	R. マイク 入力
D. VGA ポート	I. USB 3.1 ポート 13	N. サラウンド出力	
E. USB 3.0 ポート 6	J. 1Gb LAN ポート 2	O. S/PDIF 出力	

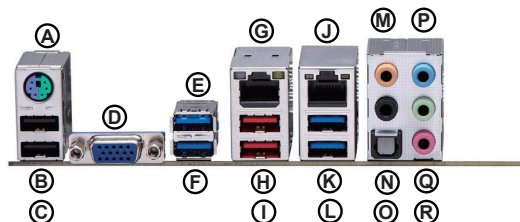

X11SRA

마더보드 레이아웃 및 기능

I/O 후면 패널

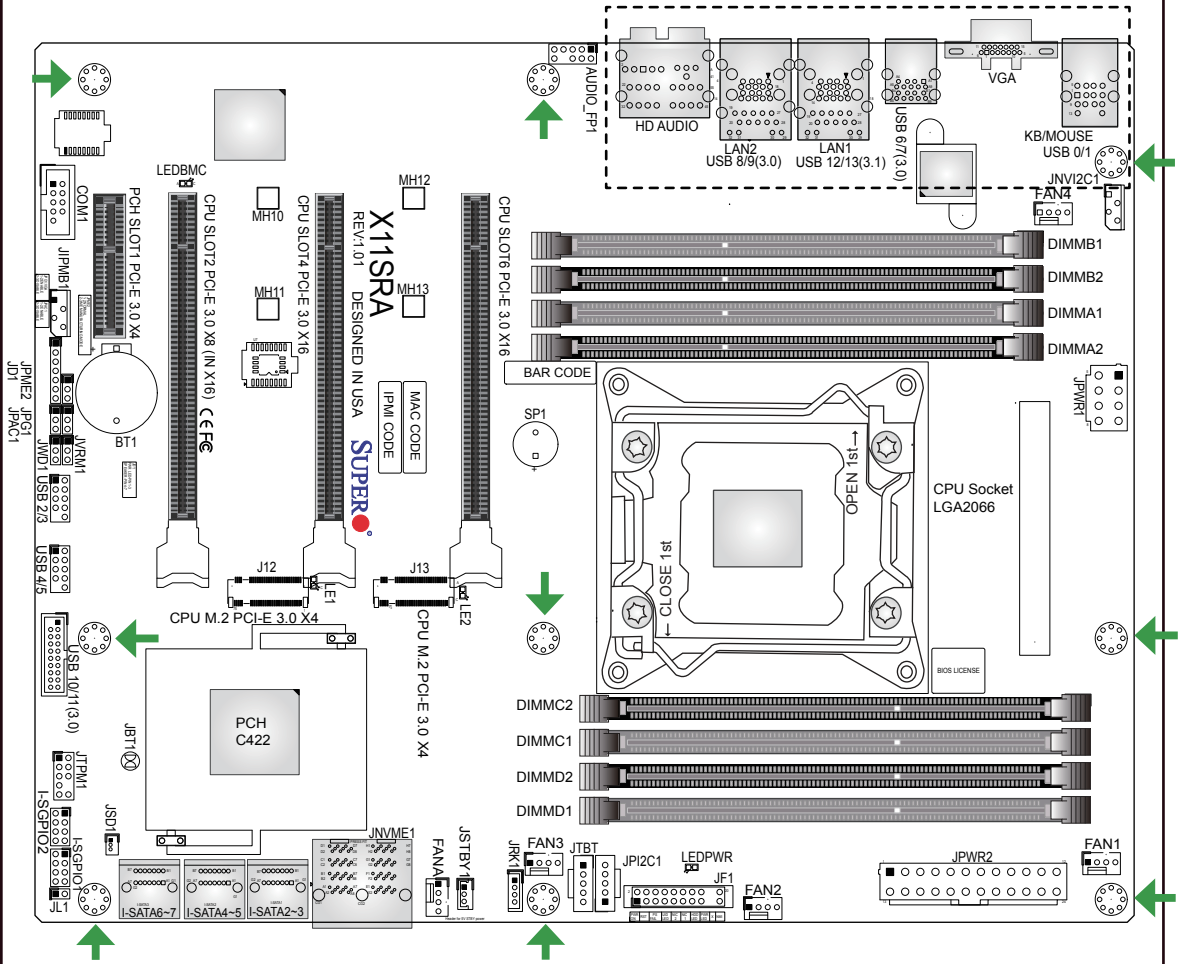

→ = 장착 구멍

포장 내용물

- Supermicro 마더보드 1개
- SATA 케이블 6개, I/O 실드 1개
- 빠른 참조 안내서 1부, 드라이버 CD 1개

점퍼 및 커넥터

점퍼		
점퍼	설명	기본값
JBT1	CMOS 지우기	열람: 기본, 닫힘; CMOS 지우기
JPAC1	오디오 사용	핀 1-2(사용)
JPG1	VGA 사용	핀 1-2(사용)
JPME2	제조 모드 선택	핀 1-2(기본)

커넥터	
커넥터	설명
AUDIO_FP1	전면 패널 오디오 헤더
BT1	온보드 배터리
COM1	COM 헤더
FAN1 ~ FAN4, FANA	시스템/CPU 팬 헤더
HD 오디오	고해상도 오디오 헤더
I-SATA2/3, I-SATA4/5, I-SATA6/7	SATA 3.0 커넥터
I-SGPIO 1/2	직렬 링크 일반용 I/O 헤더
J12	M.2 PCI-E 3.0 x4 슬롯
J13	M.2 PCI-E 3.0 x4 슬롯
JD1	스피커/전원 LED 표시등(핀 1-3: 전원 LED, 핀 4-7: 스피커)
JF1	전면 제어판 헤더
JIPMB1	시스템 관리 버스 헤더(IPMI 전용)
JL1	새시 침입 헤더
JNVME1	NVMe 커넥터(2개의 커넥터 지원)
JNVI2C1	NVMe I2C 헤더
JPI2C1	전원 I2C 시스템 관리 버스(전원 SMB) 헤더(X11SRA-F/-RF 전용)
JPWR1	+12V 8핀 CPU 전원 커넥터(필요)
JPWR2	24핀 ATX 메인 전원 커넥터(필요)
JRK1	Intel® RAID 키 헤더
JSD1	SATA 디스크 온 모듈(DOM) 전원 커넥터
JSTBY1	대기 전원 헤더
JTBT	Thunderbolt 헤더
JTPM1	신뢰할 수 있는 플랫폼 모듈(TPM)/포트 80 커넥터
LAN1/LAN2	LAN1: 5기가비트(RJ45) LAN 포트, LAN2: 1기가비트(RJ45) LAN 포트
MH10 ~ MH13	M.2 고정 나사
SLOT1	PCI-E 3.0 x4 PCH 슬롯
SLOT2	PCI-E 3.0 x8 (IN x16) CPU 슬롯
SLOT4, SLOT6	PCI-E 3.0 x16 CPU 슬롯
SP1	내장 스피커/버저
USB 0/1	후면 패널 USB 2.0 포트
USB 2/3, USB 4/5	전면 액세스 USB 2.0 헤더
USB 6/7, USB 8/9	후면 패널 USB 3.0 포트
USB 10/11	전면 액세스 USB 3.0 타입 A 헤더
USB 12/13	후면 패널 USB 3.1 포트
VGA	후면 패널 VGA 포트

참고

- 본 빠른 참조 안내서에서 사용된 그래픽은 참조용으로만 사용하십시오. 실제 구성품은 본 안내서에 표시된 도면과 똑같지 않을 수 있습니다.
- 정퍼, 커넥터, LED 표시등, 메모리 지원 및 CPU/마더보드 설치 지침에 대한 자세한 내용은 사용 설명서의 2장을 참조하십시오.

CPU 설치

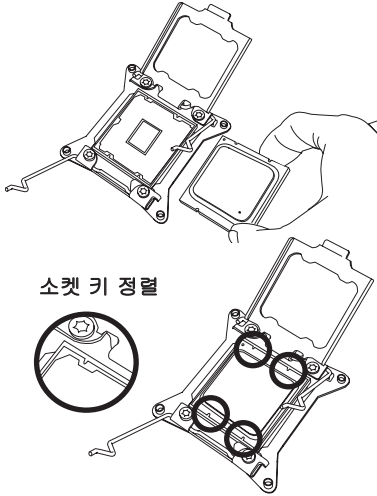

방열판 설치

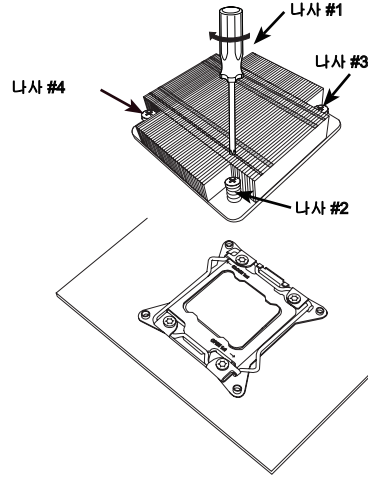

전면 제어판(JF1)

	1	2	
전원 버튼	○	○	접지
초기화 버튼	○	○	접지
3.3 V	○	○	정전 LED
빨간색+ (파란색 LED 음극)	○	○	파란색+ (OH/팬 고장)
3.3V 대기	○	○	NIC2 활성화 LED
3.3V 대기	○	○	NIC1 활성화 LED
3.3V 대기	○	○	HDD LED
3.3V	○	○	전원 LED
X	○	○	X
NMI	○	○	접지
	19	20	

	1	2	
Power Button	○	○	Ground
Reset Button	○	○	Ground
3.3 V	○	○	Power Fail LED
Red+ (Blue LED Cathode)	○	○	Blue+ (OH/Fan Fail)
3.3V Stby	○	○	NIC2 Activity LED
3.3V Stby	○	○	NIC1 Activity LED
3.3V Stby	○	○	HDD LED
3.3V	○	○	PWR LED
X	○	○	X
NMI	○	○	Ground
	19	20	

후면 패널 I/O 커넥터

A. PS/2 키보드/마우스 포트	F. USB 3.0 포트 7	K. USB 3.0 포트 8	P. 라인 입력
B. USB 2.0 포트 0	G. 5Gb LAN 포트 1	L. USB 3.0 포트 9	Q. 라인 출력
C. USB 2.0 포트 1	H. USB 3.1 포트 12	M. 중앙/LFE 출력	R. 마이크 입력
D. VGA 포트	I. USB 3.1 포트 13	N. 서라운드 출력	
E. USB 3.0 포트 6	J. 1Gb LAN 포트 2	O. S/PDIF 출력	

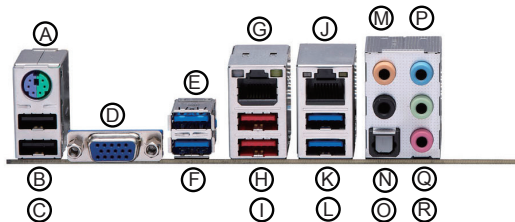

X11SRA



MNL-2005-QRG-100

© 2017 Supermicro Computer, Inc. All rights reserved. Reproduction of this document whether in part or in whole is strictly prohibited without Supermicro's written consent. All Trademarks are property of their respective entities. All information provided is deemed accurate at the time of printing; however, it is not guaranteed.